Haier

Air-Cooled Modular Chiller

Installation, operation and technical manual



Heat pump / Cooling only

R22 refrigerant

33KW, 65KW

3PH, 380V~400V, 50Hz

Haier Commercial Air Conditioning

TABLE OF CONTENTS

1. Nomenclature.....	3
2. Product character.....	3
3. Specifications.....	5
4. Dimension data.....	7
5. Installation and debugging.....	8
6. Safety precaution.....	9
7. Refrigerant circuit.....	10
8. Water system installation diagram.....	11
9. Auxiliary electric heating function control.	12
10. Water pump operation control(valid when water pump and the unit controlled simultaneously).....	12
11. The terminal simultaneous control.....	12
12. Wiring diagrams.....	13
13. Wired controller functions.....	15
14. Operation introduction.....	19
15. External wiring of UHR-820 type control board.....	22
16. Control functions.....	23
17. Controller specs.....	25
18. Malfunction and troubleshooting.....	25
19. Water quality management.....	26
20. Daily maintenance.....	26

1. Nomenclature

Code Explanation for chiller

1	2	3	4	5	6	7	8	9	10					
Chiller system	Compressor type	Capacity (KW)				Product type		Unit character	Suitable voltage	Design number				
C	Hermetic scroll	A	1	0	6	Heat pump	R22	A	Air cooled	A	100-115V/60Hz	1	Fixed frequency	A-G
	Hermetic rotary	B	0	2	3		R407C	B	Water cooled	W	220-240V/50Hz	2	Inverter	H-Q
	Hermetic single screw	C	0	0	1		R134a	C			100V/50Hz	3	DC inverter	R-Z
	Hermetic twin screws	D					R123	D			220V/60Hz	4		
	Hermetic reciprocating	E				Cooling only	R22	M			110V/50-60Hz	5		
	Hermetic absorption	F					R407C	N			220V/50-60Hz	6		
	Semi-hermetic scroll	G					R134a	P			127V/60Hz	7		
	Semi-hermetic single screw	H					R123	Q			240V/50Hz	8		
	Semi-hermetic twin screws	I									110-220V/50-60Hz	9		
	Semi-hermetic reciprocating	J								380-400V/50Hz	N			
	Semi-hermetic absorption	K								415V/50Hz	M			
	Semi-hermetic centrifugal	L												
	Opened	M												

2. Product character

- a. Installation conveniently, no need the special machine room and water tower; can be installed on the roof or out of the room. Widely application for cinema, hospital, hotel, school, commercial building, etc.
- b. Utilize flexible scroll compressor. And adopts dual compressors in parallel technology. The master unit will control both compressors run or stop due to the water outlet temp. Optimum refrigerant distribution technique and minimum-deformation design. Adoption of rolling bearing and non-lubricated bearing. Excellent heating effect at low temperature. Broad range of working temperature and suitability for high condensation temperature.
- c. Shell & Tube and U type inner grooved finned coil heat exchanger.
High efficient water side heat exchanger: in cooling, the water side heat exchanger is as evaporator; in heating, it is as condenser. The freezed water flows outside of the pipe, and the refrigerant flows in the pipe. Optimum design, reliable operation, reasonable structure, perfect performance.
- d. Central control technology, indoor unit be connected with controller by dual core non-polar wire. The indoor units can be controlled individually or simultaneously, more convenient, more energy saving.
One central air conditioning system can include max. 8 sets (65 series) or 16 sets (100 series) of module unit. Through the dip switch on PCB you can set unit No. of every module unit, and every unit is connected by RS485 port. Compact structure, convenient for electric installation.
- e. Fan coil simultaneous control technology: indoor fan coil can be controlled individually or centrally.

Every indoor unit is connected to the individual controller or central controller through dual-core non-polar wire to realize the central control. When one indoor starts up, the central air conditioning system will start up automatically. When all indoors arrive the set temperature, the master unit will stop. Energy saving.

- f. Auto check technology: The system can check the operation status automatically; all kinds of sensors will transmit the operation parameters to the chip. By pressing the buttons, all the parameters can display on the liquid crystal screen. When the unit occurs failure in operation, the failure will display on the LED so that the malfunction can be solved soon.
- g. Password control function: According to the user setting, the password control function can be used. Therefore the control to the unit will be more reliable and more flexible.
- h. Equipped with RS-485 physical connector, perfect network communication ability.
- i. Module structure design, the system can be produced or transported as module unit. Every system is independent, and they are spare part for each other, however which cooling circuit is abnormal, the other systems do not be affected by the abnormal system, and furthermore they will run in shape. Module structure can reduce the cost of transport and installation greatly, more convenient.
- j. Heat exchanger of air side is designed much larger, enlarge heat transmission area, lower the temperature drop of transmission. Consequently, the chiller can run in cool mode even at high temperature of 45celsius degree in summer, and also can run in heat mode at low ambient temperature of -15celsius degree in winter with good performance.
- k. Safety and protection devices: phase reverse protection device, high and low pressure switch, freeze protection device, overheat protection device, overload protection device, etc. Also, with Timer ON/OFF, AUTO operation, defrosting, etc. functions.

3. Specifications

Model			CA0035AANC	CA0035MANC	CA0070AANC	CA0070MANC
Nominal cooling capacity		KW	33	33	65	65
Nominal heating capacity		KW	35	/	70	/
Refrigerant charge		kg	11	9.4	18	18
Rated power input		kw	11.87	11.96	21.24	21.52
Rated current		A	20	20.2	35.9	36.3
Power supply			3PH, 380V, 50Hz			
Running control method			fully automation			
safety&functional protection			high/low pressure protection, water stop delay protection, anti-frezed, motor overload protection, overheat protection, lack phase/phase sequence protection			
compressor	type/manufacture		soft scroll			
	quantity	set	2	2	4	4
	rated power	KW	10.6	10.6	21.2	21.2
Fan	type		specical motor and fan blade			
	quantity	set	1	1	2	2
	rated power	KW	0.75	0.75	1.5	1.5
External dimension	length	mm	1325		2185	
	width	mm	1000		1000	
	height	mm	1850		1850	
Refrigerant charge		kg	11	9.4	18	18
Refrigeration control method			thermostatic expansion valve			
Water side heat exchanger			plate type heat exchanger, working pressure 1.0MPa		shell & tube heat exchanger, working pressure 1.0MPa	
Air side heat exchanger			cross finned coil, inner grooved copper pipe&dydrophilic aluminum finned coil			
Water flow		m3/h	6	6	12	12
Water resistance		kPa	110	110	80	80
Water pipe diameter		mm	65	65	65	65
Net weight		kg	400	390	755	735
Running weight		kg	460	450	860	840
Nominal working condition (cooling):water inlet temp. 12℃, water outlet temp. 7℃, ambient temp. 35℃。 Nominal working condition (heating):water inlet temp. 40℃, water outlet temp. 45℃, ambient temp. (DB)7℃, (WB)6℃						

units running temp. range: -7~43℃

circular water dirt coefficient 0.018m²·℃/kW

can max. connect module chillers 16 pcs

when multi-module chillers combined,which total water inlet/outlet pipe diameter refer to follows:

qunatity	2	3	4	5	6	7	8	9	10	11	12	13	14	15	16
diameter	65	80	100	100	125	125	150	150	150	200	200	200	250	250	250

4.Dimension data

4.1 Installation dimension

CA0035AANC

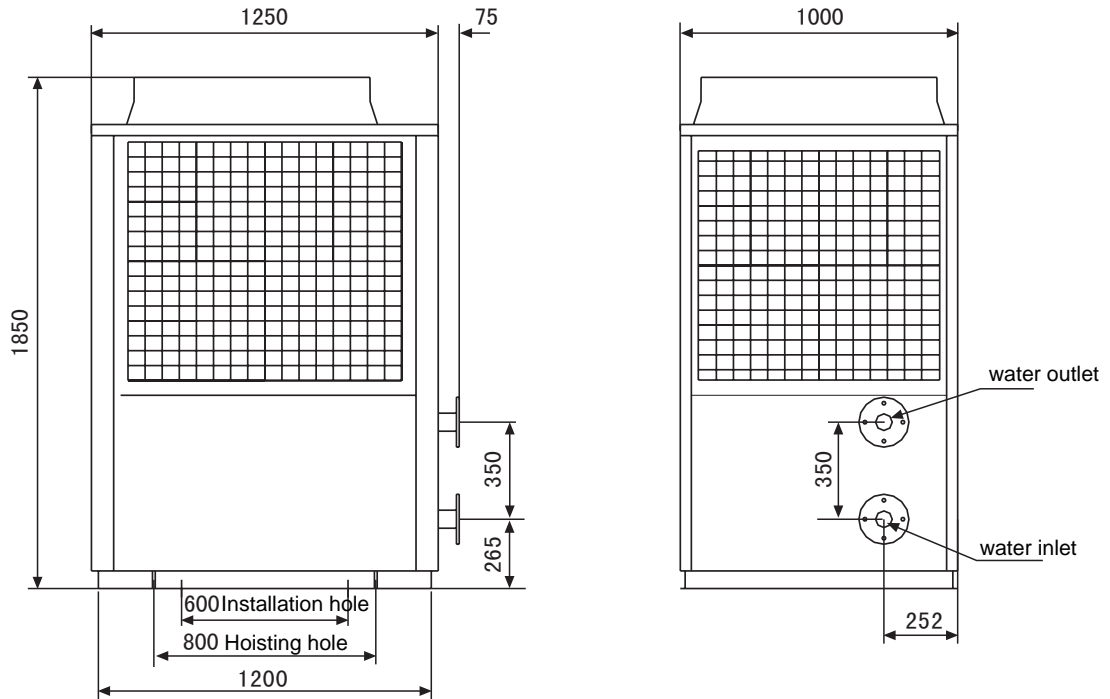

CA0070AANC/MANC

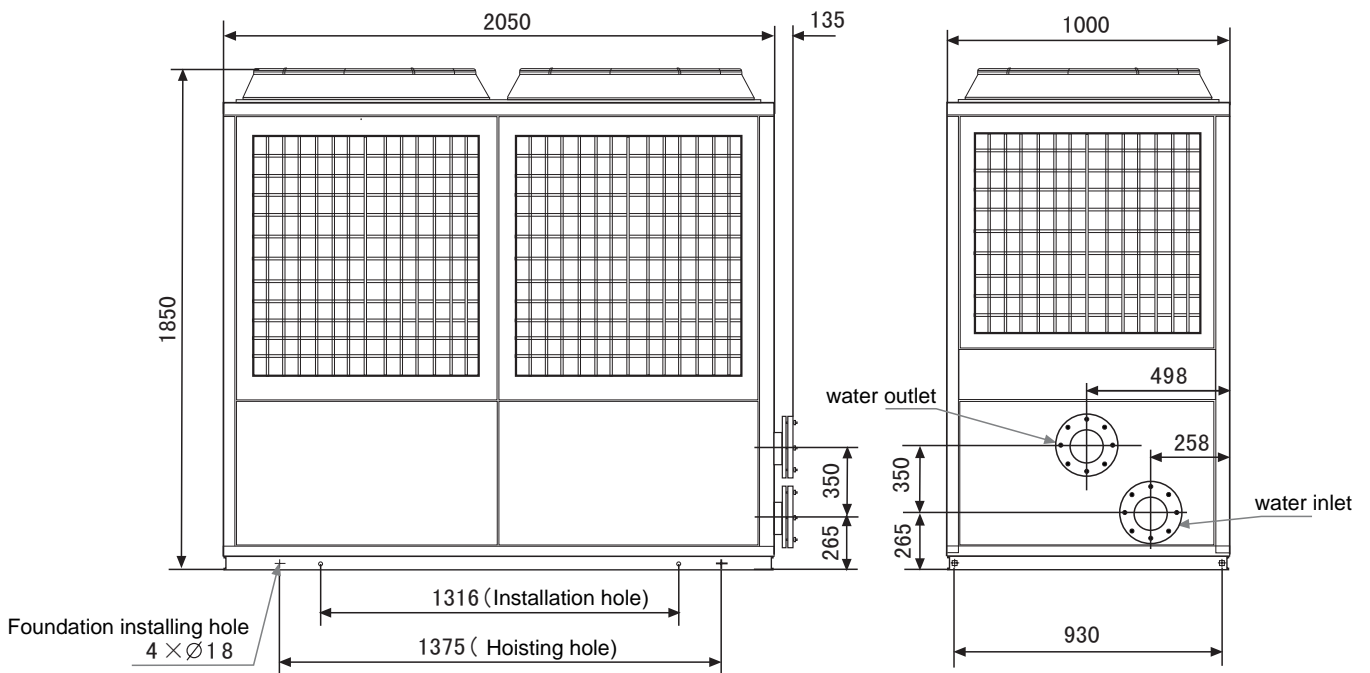

4.2 Foundation dimension

4.2.1 The bearing capacity of the foundation shall be designed according to the unit's operation weight.

4.2.2 The foundation can be beam channel (designed by the installer according to the unit outline dimension) or concrete structure, and the surface of the foundation shall be flat.

4.2.3 A 10~20mm rubber anti-vibration cushion shall be used between unit and foundation.

4.2.4 The unit can be fixed on the foundation by using anchor bolt with 16 or 18mm diameter.

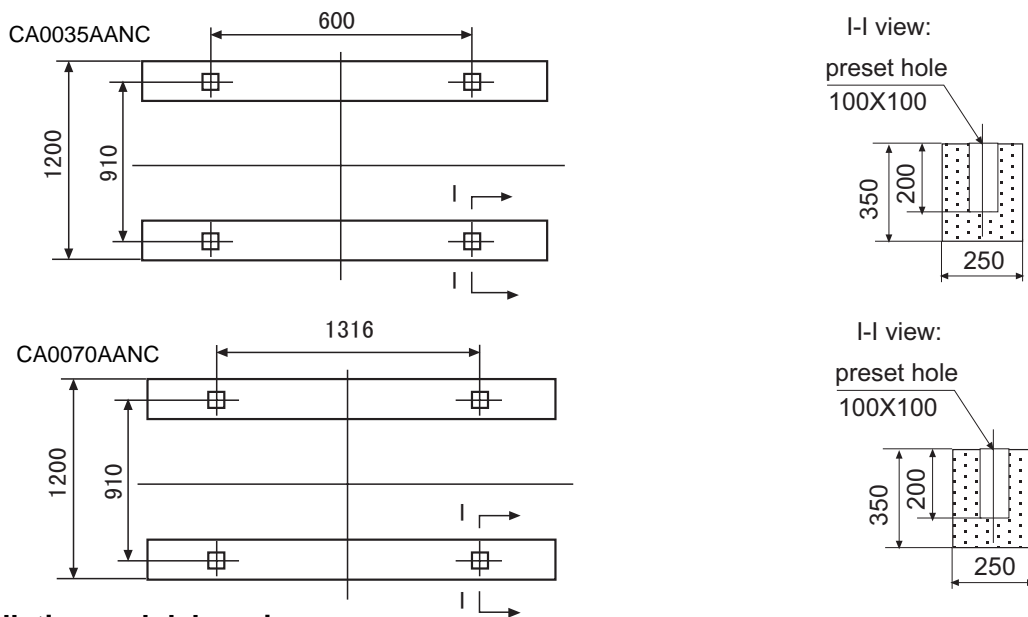

5. Installation and debugging

5.1 Freight Check

All the units are tightly fastened on the wooden pallet by the bolts. Before leaving factory, the units are all checked and pre-filled with refrigerant and refrigerant oil, both of which are the precise amount the unit operation needs. When user receives the product, he shall check it carefully to confirm if there is product damage in transportation and to confirm all the pre-ordered parts are received.

If there is any damage, he shall immediately inform the transportation person and claim for compensation according to relevant clauses. If there is problem except for surface damage, he shall immediately inform our company.

5.2 Transportation

In order to be convenient to carry the unit, the user shall use forklift or crane. When using crane, there shall be proper partition to protect the top and side panel of the unit (as Figure shown). During carrying, the unit shall be kept level, and the gradient shall not exceed 30°. Try to avoid units damage due to improper operation.

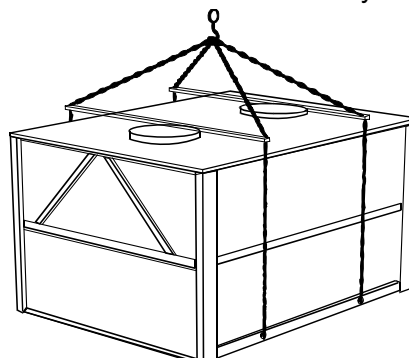

5.3 Unwrap the packaging

After putting the unit on the site, cut the packing strap and remove the outer crate. Unscrew the tightening bolt and remove the wood pallet from the bottom of the unit.

5.4 Selection of Installation Place

5.4.1 The installation place shall be plane, the foundation surface shall be flat, and the supporting surface can bear the operating weight of the unit.

5.4.2 The unit shall not be installed in a place where there is too much dust, corrosive gas, high humidity or insects gathers easily, fallen leaves and other contaminative matters.

5.4.3 There shall be over 1.5m space around the unit to be convenient for ventilation and maintenance.

5.4.4 Try to keep the unit away from sunshine and rain, it is recommended to cover the unit with shed, but be sure there is a space over 3m above the air outlet for releasing heat easily.

5.4.5 An anti-vibration cushion about 10-20mm shall be equipped between the unit and the foundation.

After adjusting length, fasten the anchor bolt.

5.4.6 For the heat pump unit, there shall be a drain for the condensate.

5.4.7 The installation and thermal insulation of the water pipes of the air conditioning system shall be designed and instructed by the professionals and shall implement the relevant regulations of the Installation Standard for HV & AC.

5.4.8 The external water pipe system must be equipped with anti-vibration hose, water filter, electronic water cleaner, check valve, drain valve, discharging valve, stop valve and expansion tank, etc. The expansion tank shall be installed 1-1.5m higher than the system top, and its capacity is about 1/10 of the total water amount of the system. The air release valve shall be installed between the top of the system and the expansion tank, and the water tank and the pipe shall be thermal insulated.

5.4.9 The water supply system must match the water pump with proper water flow and proper head to ensure the supply for the unit normally.

5.4.10 The unit must be equipped with a water filter in front of the water inlet pipe and use the mesh with 16~40-mesh filter.

5.4.11 The anti-vibration hose must be used between water pump and unit, between water pump and water pipe of system. At the same time, the pipes and the water pump shall have bracket to prevent the unit from receiving force.

5.4.12 leaning and heat preservation of system must be done before connecting the pipe with the unit.

5.4.13 Recommend that maintenance space among units should be over 400mm.

6. Safety Precautions

6.1 The system pressure and electric parts will cause danger to the installation and maintenance of the air conditioner, so only the authorized personnel with qualification can perform the installation, operation and maintenance of the air conditioner.

6.2 Please comply with the protection measures and safety warnings marked on the documents, labels and nameplate on the unit.

6.3 Please comply with various safety regulations, wearing safety glasses and working gloves, and when welding, wear the fireproof clothes.

Warning: Before maintaining the unit, cut off the main power supply of the unit, otherwise electric shock will cause.

6.4 When maintaining, only the original parts shall be used and pay attention to correct installation, and the parts must be installed in their original position.

6.5 During unit operation, the temperature of some parts of the refrigerant circuit may exceed 70°C, so that the untrained personnel shall not make bold to remove the protection panel of the unit.

6.6 Unit shall not be installed in the air containing explosive gases.

6.7 If the heat pump type unit operates under the condition below 0°C, it must be installed in a place 300mm higher than the ground, which can not only prevent the bottom plate from freezing, but also prevent the accumulated snow from reaching this height to influence the unit's normal operation. The unit shall be installed on a flat surface (the max. deviation of the ground level shall not exceed 2mm/m.)

7. Refrigerant system

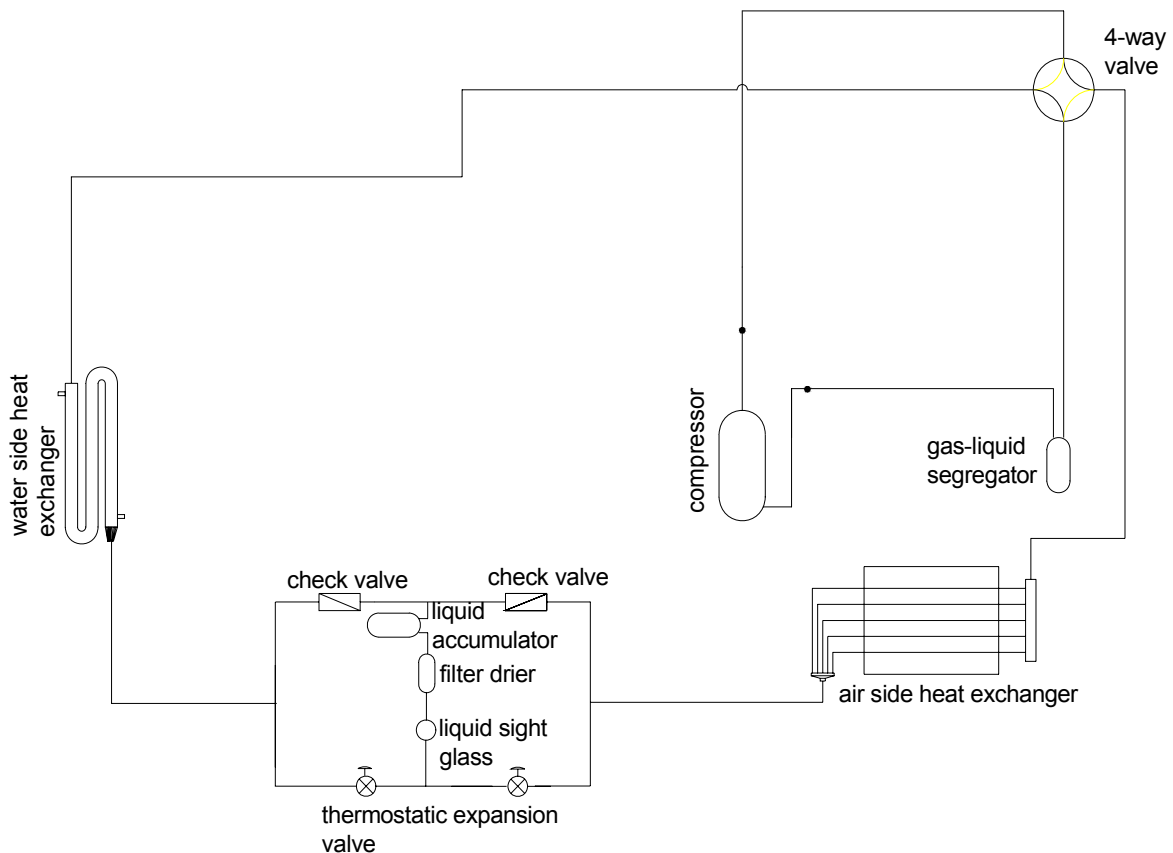

8. Water system installation diagram

Water System Installation Diagram

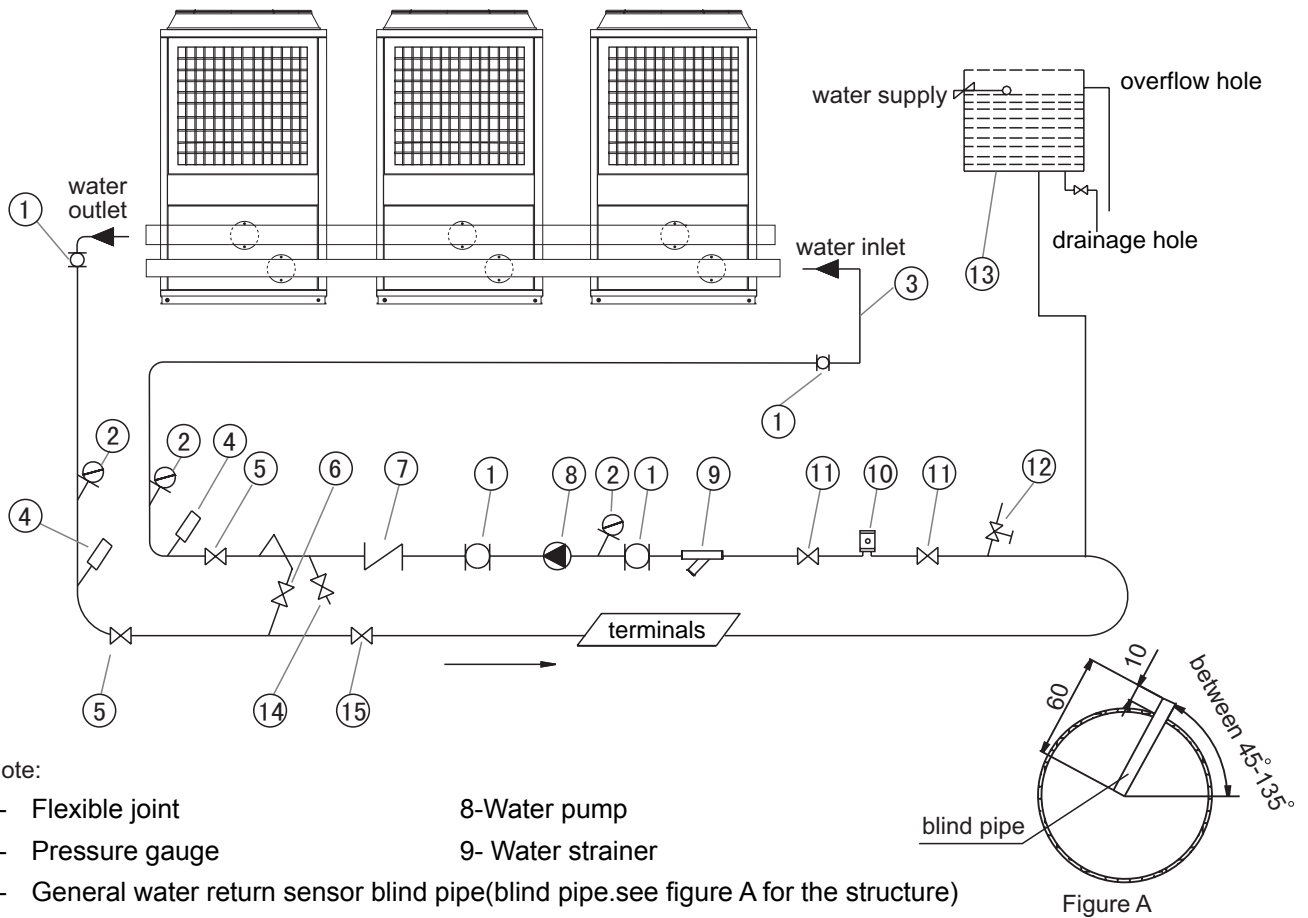

Note:

- | | |
|--|--|
| 1- Flexible joint | 8-Water pump |
| 2- Pressure gauge | 9- Water strainer |
| 3- General water return sensor blind pipe(blind pipe.see figure A for the structure) | 10- Electronic water cleaner |
| 4- Thermometer(0-100℃) | 12-Auto discharge valve(highest point of water system) |
| 5、11、15-Stop valve | 13-Expansion tank |
| 6- Bypass valve | 14-Water outlet water |
| 7- Check valve | |

When cycle water runs for the first time,close the inlet/outlet valve(No.5) and open the by-pass valve(No.6).when water pump works for a while,clean the water strainer.after confirmed that there is no impurity in the external cycle system,open inlet/outlet valve(No.5) and the by -pass valve(No.6).Then,the unit is in normal operation.

Note:

After unit installation finished,master module chiller’s general water return sensor in the main module must be fixed on the general water return pipe,Pay attention that a section of blind pipe(φ 8, L=6mm) be reserved for the installation of temp. sensor in site design and that the insert length of blind pipe is 50mm.When installing the sensor,place the sensor beneath the blind pipe and inject some refrigeration oil into the blind pipe.The level of refrigerant oil should be at least 10mm over the sensor.To minimize heat transfer error,it is necessary to adopt heat insulation measures.

Pipe dimension: the pipe dimension will be different according to the module quantity. Please install as follows:

70+35, 70*2→DN65; 70*2+35, 70*3→DN80;
70*3+35~70*5→DN100;70*5+35, 70*6→DN125.

Water pipe direction: when module quantity is below 3 sets, select the connection of single row type or multi-row type; but when module quantity is no less than 4 sets, must select the single row type connection.

9. Auxiliary electric heating function control

The auxiliary electric heating function will be performed in low ambient temperature. Connect the water inlet/outlet pipe with auxiliary electric heater to the total water inlet/outlet pipe, in the electric control box of the master module, there is the control port of auxiliary electric heating (only with 220V output, not supply the electric heating control part). After compressor starts up, when the actual ambient temp. is 7 degree lower than the "electric heating startup temp. ", and water outlet temp. is 5 degree lower than "heating set temp.If the two conditions can be met, electric heating will work. When the actual ambient temp. is 15 degree higher than " ambient temp. of allowable electric heating startup" or compressor stops, the electric heating will stop.

10. Water pump operation control(valid when water pump and the unit controlled simultaneously)

In the electric control box, there is the freezed water pump simultaneous control port (only with 220V output, not supply the water pump control part). When the unit is in standby state, water pump will not start up; when the unit enters working state from standby state, start up water pump firstly; when the unit enters standby state from working state or stop state, 120seconds later, water pump will stop automatically. In stop state, when water outlet temp. is no more than 3 degree and ambient temp. is under 5 degree. the water pump will start up,then a module (A module)starts heating mode,when water outlet temp.reach to 25 degree, heating mode will stop,and anti-freezed will quit.

Note: When multiple units utilize one set of water system, as long as the units start up, all the water pumps will start up (except for the spare water pump), and forbid to confirm the water pump quantity according to the running unit quantity. Twater pump selection should satisfy units' requirement:the actual water flow and nameplate value should be in the range of (rated water flow $\pm 30\%$).

11. The terminal simultaneous control

Connect the passive N.O. port of the terminal controller to the simultaneous control port (YK) in the wired controller of the master module unit. When the unit is running and the controller is in simultaneous control state, when one of terminal unit starts up, the chiller system will start up automatically. When all the terminal units stop, the chiller system will stop later.

When in electric wiring, please pay attention to the following:

- The wires are the power supply cable and the communication wire. The wires with the unit have been fixed properly, and should not be modified by the user.
- Ensure that the communication wire is earthed on one point after the unit is earthed well; if the unit is not earthed properly, the communication will be interfered. The communication wire should be twisted-pair, with diameter AWG20~22, and over 10cm far from the high voltage wire.

The unit running current is as below table:

Unit type	Rated current	Max. current	Rocked current	Cable section for reference
CA0070AANC	35.9A	45A	(130*2)A	3×16mm ² +2×8mm ²
CA0070MANC	36.3A			
CA0035AANC	20A	23A	130A	3×10mm ² +2×8mm ²
CA0035MANC	20.2A			

12. Wiring diagrams

a. The unit wiring diagram

35:

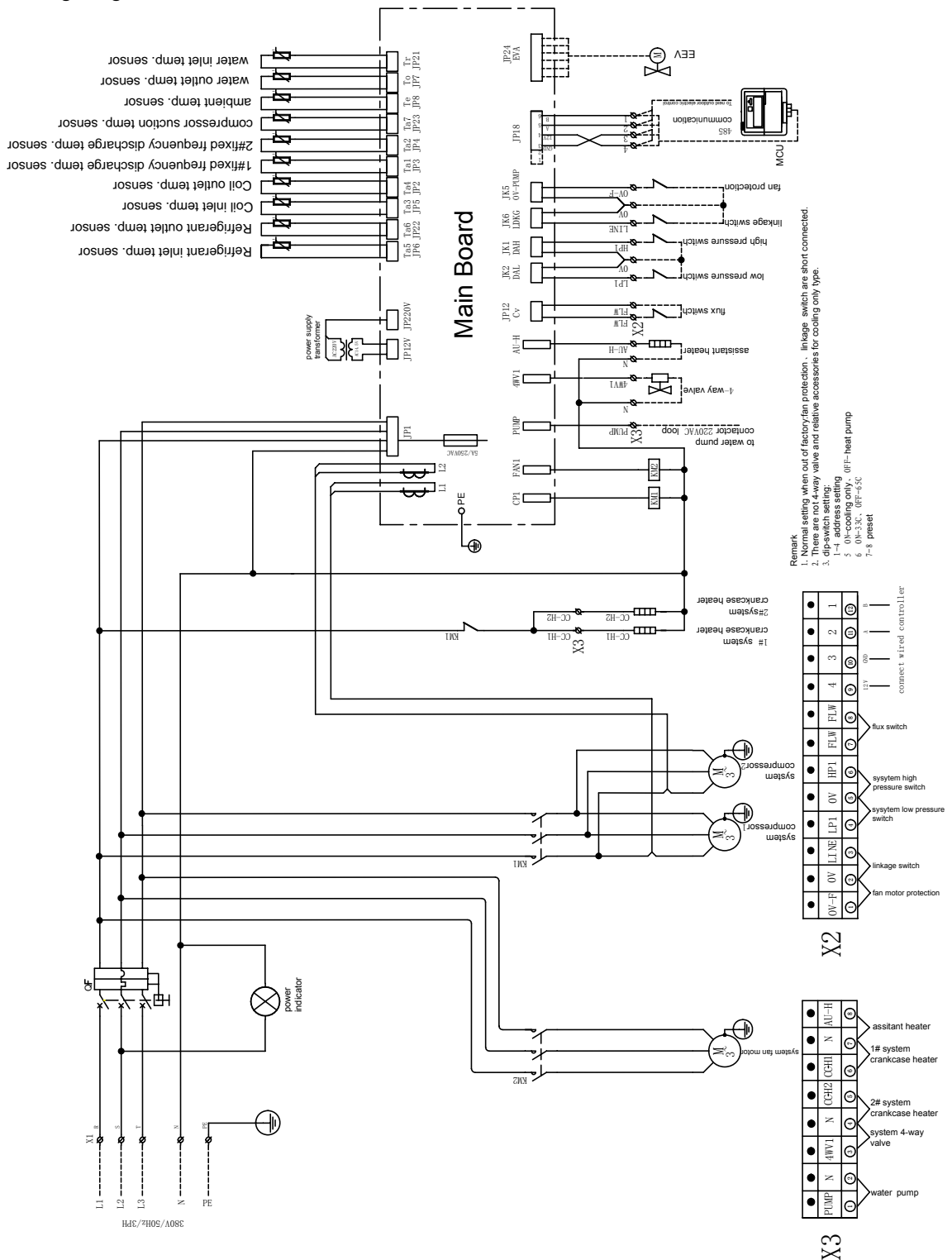

70:

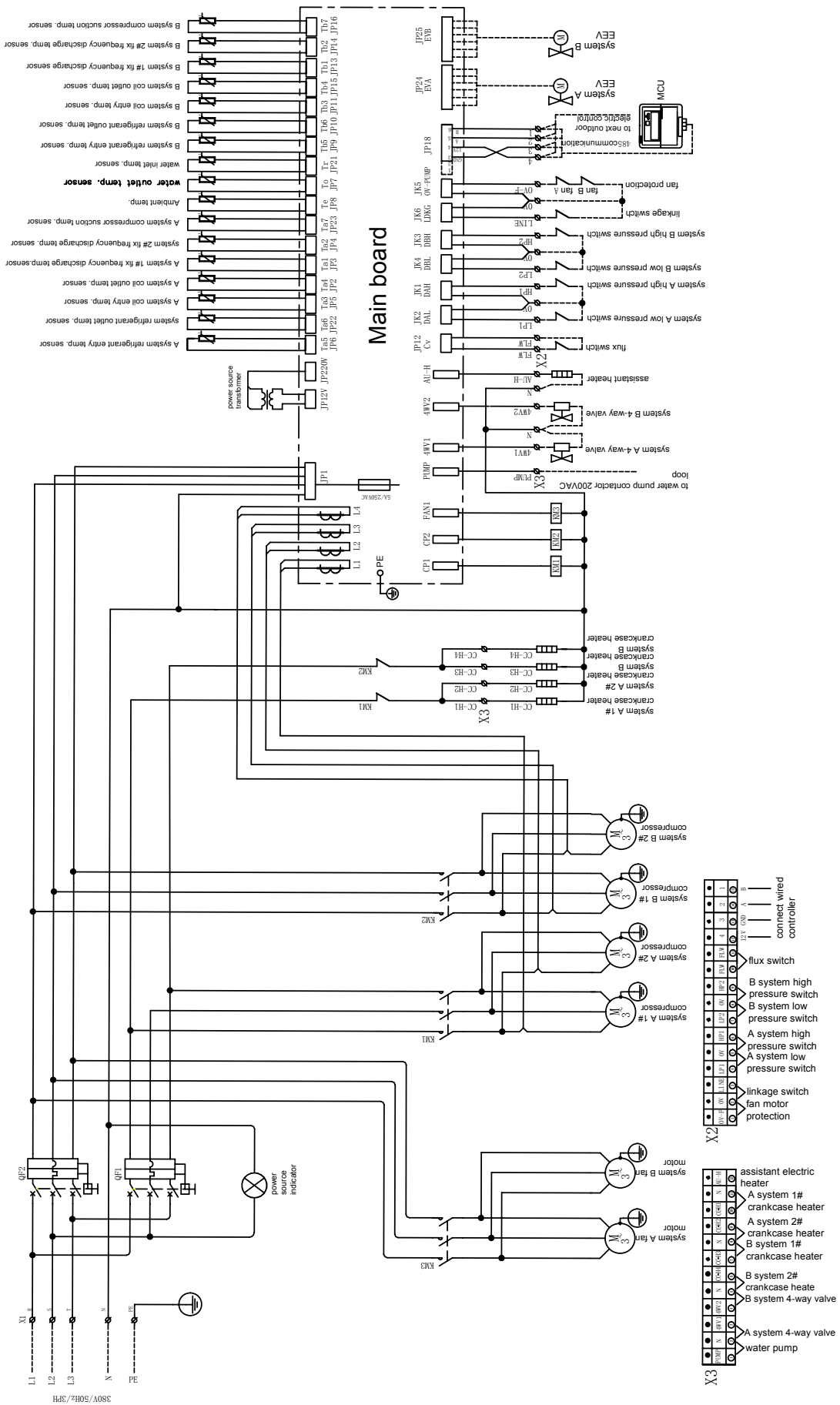

b. The driving wiring diagram

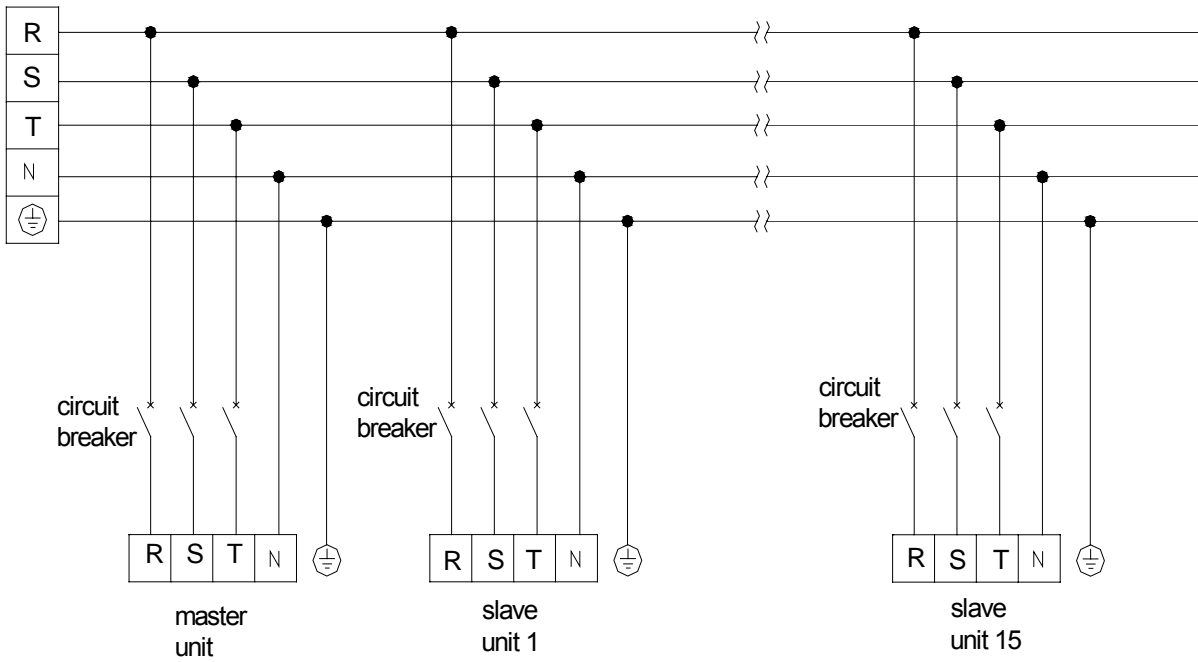

13. Wired controller functions

1. WIRED HANDSET LAYOUT

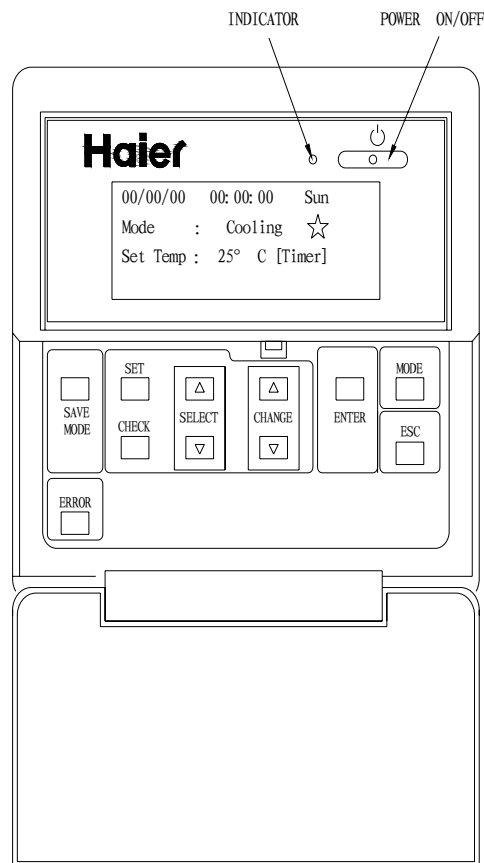



1.1 Wired Handset General Instruction

- a. Input power supply: 12VAC±10%; Power consumption<1.5W。
- b. Communication mode: RS-485 standard COM, maximum distance 1200m;
RS-232 standard COM (provision)
- c. LCD Display: 4 rows of 22 letters each.
- d. Buzzer: When power on, buzzer beeps once;
When operating key pad, every entry beeps once;
When alarm triggers due to error, buzzer beeps 3 times consecutively.
- e. Backlight: 20s.
When keying in or when error occurs, the intensity of the backlight is 20s.
- f. LED Indicator Light: Lighted when operating.

1.2 Key Pad Instruction

- a. **【ON/OFF】**
When the system's power is switched on, press ON to start operation. Press again to reverse the status of operation.
- b. **【MODE】**
To select mode of operation and switching from cooling to heating.
And vice-versa.
- c. **【SAVE MODE】**
Selecting the SAVE MODE will enable the system to operate with energy-saving condition whereby the set temperature of returned water will be set at 15 °C during cooling and at 37 °C during heating.
- d. **【CHANGE】**
To change the operating parameters, press CHANGE and scroll up or down for desired parameters. When the wired handset is not in application, the CHANGE key can be used to set the temperature of the returned water.
- e. **【SET】**
To set parameters such as time, time mode, timer, press SET.
- f. **【SELECT】**
To choose menu, press SELECT and scroll up or down for the desired functions. Any selected function will appear as reversed white on the LCD.
- g. **【ENTER】**
To confirm the selected function, press ENTER. The LCD panel will display the corresponding parameters.
- h. **【ESC】**
To exit the current operation, press ESC. Each exit will return to the previous menu and finally ending at the main menu interface of the Wired Handset.

i. **【CHECK】**

To check the parameters of the modular chiller, press CHECK. Select the address of the intended chiller by scrolling up  or down . After entering the selected chiller, use the scroll keys to check the parameters and performance.

j. **【ERROR】**

To trouble shoot, press ERROR and scroll for historical error records of up to 28 cases. The same key can also be used to delete unwanted historical records.

k. WIRED HANDSET GENERAL INSTRUCTION

- a) To commence operation, use the Wired Handset to initiate start-up. The indicator light will be turned on.
- b) The mode of operation can be selected either before commencing or during the operation. The system will automatically operate based on the last mode of operation before shutdown.
On the main menu, returned water temperature can be reset using the CHANGE key. The allowable scope ranges from 10 to 25 °C for cooling and 25 to 55 °C for heating. (Lower limit for cooling is allowed)
- c) To operate energy saving mode, press SAVE MODE. The returned water temperature for cooling operation will be set at 15 °C and at 37 °C for heating.

2. MAIN MENU

when power on, The main display page is as follows:

MAIN DISPLAY

07/01/01 23: 59: 59 SUN
Mode: Cooling/Heating ☆
Set Temp: 25 °C [Timer]
Sys Error: --

First row display: Year / Month / Day / Hour/minutes / seconds /weekday

Second row display: Mode setting. Select heating or cooling mode.

☆ symbol denotes system working in tandem. System start-up can be initiated using handset or the individual control of respective zone. The lack of it denotes system start-up can only be done via handset.

Third row display: Temperature setting. For heating, select between 25 °C to 55 °C For cooling, select between 10 °C- 25 °C (lower limit is allowed).

[TIMER] denotes the setting is valid for the current day.

Forth row display: Display the system error-code and corresponding address.

When more than one error occurs on a particular module, the error with the smallest error code number will be displayed first.

When errors occur in more than one module, the error on the nearest module will be displayed first.

3.MAIN FUNCTIONS

Press [SET] to enter the main function menu.

The first three functions allow user settings. The fourth set of function is only accessible to authorized personnel.





MAIN MENU





Set Time Time mode: Weekly /Daily / Current /Disable Timer Set Parameter

3.1. To set time, press [SELECT] followed by [ENTER] to confirm.

SET TIME

YY/MM/DD:00/00/00 HR/MIN/SEC:00/00/00
--





3.2. Press [SELECT] and scroll up  or down  to choose Year / Month / Day hours/ minutes / seconds. Press [CHANGE] and scroll up  or down  to set time. Press **【ENTER】** to confirm. Revised time will be displayed on the main menu.

3.3. Press [SELECT] and scroll up  or down  for time setting mode. Press [CHANGE] and scroll up  or down  to select weekly /daily / current / disable function. When completed, press [ESC] to return to the previous menu.

3.4. Press [SELECT] and scroll up  or down  for Timer. Press **【ENTER】** to confirm.

a. To set weekly timer, press [SELECT] to choose from Monday to Sunday. Each day is allowed 2 settings of startup and shutdown. To change the time, press [CHANGE] and amend as desired. When completed, press [ESC] to return to the previous menu.

Detailed instruction as follows:;

Press [SELECT] and scroll up  or down  for desired time setting function. The selected function will be in reversed white. Press [CHANGE] to set the required time. Each pressing of the [CHANGE] key up  or down  will set the clock forward or backward by one minute, and automatically reflect forward or backward one hour after adjustment of 60 minutes. If setting appears "--:--", it denotes that the particular setting is invalid. .

After completing the four time settings, press [SELECT] to choose Timer. Repeat the process and

after completion, press [ESC] to return to the previous menu.

When completed, the modular system will operate repetitively based on the respective day setting of the week.

Note: To speed up time setting, hold down [CHANGE] or for more than one second to initiate continuous change of clock.

WEEKLY TIMER

Mon Timer1 ON :	00: 00
Mon Timer1 OFF:	01: 00
Mon Timer2 ON :	02: 00
Mon Timer2 OFF:	03: 00

Tue Timer1 ON :	--: --
Tue Timer1 OFF:	--: --
Tue Timer2 ON :	--: --
Tue Timer2 OFF:	--: --

Wed Timer1 ON :	--: --
Wed Timer1 OFF:	--: --
Wed Timer2 ON :	--: --
Wed Timer2 OFF:	--: --

Thu Timer1 ON :	--: --
Thu Timer1 OFF:	--: --
Thu Timer2 ON :	--: --
Thu Timer2 OFF:	--: --

Fri Timer1 ON :	--: --
Fri Timer1 OFF:	--: --
Fri Timer2 ON :	--: --
Fri Timer2 OFF:	--: --

Sat Timer1 ON :	--: --
Sat Timer1 OFF:	--: --
Sat Timer2 ON :	--: --
Sat Timer2 OFF:	--: --

Sun Timer1 ON :	--: --
Sun Timer1 OFF:	--: --
Sun Timer2 ON :	--: --
Sun Timer2 OFF:	--: --

- b. To set the daily timer, press [SELECT] or for the chosen days follow by [CHANGE] to set timer. When completed, press [ESC] to return to the previous menu.

DAILY TIMER

Timer1 ON :	--: --
Timer1 OFF:	--: --
Timer2 ON :	--: --
Timer2 OFF:	--: --

- c. To set timer for just the current day, press [SELECT] or for CURRENT setting follow by [CHANGE] to set timer. When completed, press [ESC] to return to the previous menu.

CURRENT

Timer1 ON :	--: --
Timer1 OFF:	--: --
Timer2 ON :	--: --
Timer2 OFF:	--: --

- d. If the timer setting function is disabled, accessing the timer setting menu is restricted.

4. SET PARAMETER

To set operating parameters, press [SELECT] or for SET PARAMETER followed by [ENTER]. A password available to authorized personnel is required.

SET PARAMETER PASSWORD

Version: GS1.0
Enter Password

- 4.1. The default password is "1234". Enter password as follows: Select PASSWORD , the first digit of the password will be in reversed white. Press [CHANGE] or to change the values accordingly. Press [SELECT] to move to the next digit. Repeat the process until all 4 digits match the password and press [ENTER] to confirm.

4.2. DEFROSTING FUNCTION

The first parameter setting menu on DEFROSTING is as below:

DEFROSTING

Defrost Time: Max 8min
Defrost Interval:----
Defrost-on Temp: -4 °C
Defrost-off Temp: 17 °C

1. To set defrost time, press [CHANGE] or to choose from 5 to 16 min.
2. To set defrost interval, press [SELECT] or for Defrost Interval followed by [CHANGE] or to set from 20 to 120 mins. If setting appears as "----", the defrost interval setting is based on self-adaptive mode.
3. To set the temperature at which to commence defrosting, press [SELECT] or for Defrost-on Temp followed by [CHANGE] or to set from -15 to 0 °C.
4. To set the temperature at which to end defrosting, press [SELECT] or for Defrost-off Temp followed by [CHANGE] or to set from 10 to 20 °C.

4.3. SAFETY FUNCTION

Press SELECT to move to second parameter setting on safety.

SAFETY FUNCTION

Water-out Alarm: 3 °C
Set Temp Limit: 10 °C
Antifreeze Temp: 3 °C
Auto-restart: Disable/Enable

1. To set the temperature of water-out at which to trigger alarm, press [SELECT] for Water-out Alarm followed by CHANGE to set from 2 to 9 °C.
2. To set the lowest temperature of the returned water towards which the system will maintain, press [SELECT] or for Set Temp Limit followed by [CHANGE] or to set from 5 to 12 °C.

Note: To set the returned water temperature <10 °C for special cooling application, specific additive must be used for chilled water system and the setting be handled by qualified technical personnel.

3. To set the temperature at which to trigger anti-freeze safety function, press [SELECT] for

Antifreeze Temp followed by [CHANGE] or to set between 0 to 9 °C.

4. To enable the system to automatically restart after interruption of power supply, press [SELECT] or for Auto-restart followed by [CHANGE] or to set "ENABLE". If "DISABLE" is chosen, the system will remain shutdown after power resumes.

4.4. LOAD CONTROL

To apply suitable time duration for starting up or shutting down according to varying numbers of chiller modules in use, press SELECT to move to Load Control setting menu to change the Load or Unload Parameter. This program is normally preset for self-adaptive application as denoted by --.

LOAD CONTROL

Load Parameter : ——
Unload Parameter: ——
Mfg Parameter
Set Password

1. To program the startup duration, press [SELECT] for Startup Parameter followed by [CHANGE] or to set from 01 to 16. If the parameter appears as "——", the setting is invalid and is on self-adaptive mode.
2. To program the shutdown duration, press [SELECT] or for Shutdown Parameter and repeat the above process.
3. To access the manufacturer's setting, press [SELECT] or for Mfg Parameter followed by [ENTER], and key in the password provided by the manufacturer.

MFG PARAMETER PASSWORD

Version: GS1.1
Enter password

The default password is "2008". To key in password, repeat password entry process. Press [ENTER] to access the Mfg parameter to check for the number of days the system has been operating and the remaining number of days under the current setting. User may change the parameters and password if required.

Note: To enter the Manufacturer's Password, use only [SELECT] and and [CHANGE] or process to input the password.

MFG PARAMETER SETTING MENU

Days Run: 00
Days Valid: ----
Language: English
Set Password

- a. To set the number of days for the system to operate, press SELECT for Days Run followed by [CHANGE] or to set from 00-1999.
- b. To find out the remaining days of valid operation, press [SELECT] or for Days Valid followed by [CHANGE] or to set between 00–1999. (For the purpose of the service provider to have control over their users, this function should only be available to the service provider.)
- c. To set Language, press [SELECT] or for Language followed by Press [CHANGE] or to choose English/Chinese.
- d. To set password, press [SELECT] or for PASSWORD followed by [ENTER]. Press [SELECT] or followed by [CHANGE] or to change the password from 0 to 9. Press [ENTER] to confirm and return to the main menu.

MFG PARAMETER PASSWORD

Version: GS1.1
Enter password

When completed, press [ESC] to return to the previous menu.

4. To set password, press [SELECT] or for PASSWORD followed by [ENTER]. Press [SELECT] or followed by [CHANGE] or to change the password from 0 to 9. Press [ENTER] to confirm and return to the main menu.

SET PARAMETER PASSWORD

Version: GS1.0
Enter Password

4.5. TESTING & INTEGRATION

Press SELECT to move to the next Set Parameter menu.

TESTING & INTEGRATION

```
Test Module: 00
BPHE anti-frozen: DISABLE/ENABLE
BA Control: DISABLE/ENABLE
Mfg Setting
```

1. Press [SELECT] or for Test Module. Press [CHANGE] or to choose from 0~15 addresses of the chiller modules and confirm with [ENTER] to access the Test Module.

TEST MODULE

```
Set EXV1: 00
EXV1 Manual: Disable/Enable
Set EXV2: 00
EXV2 Manual: Disable/Enable
```

```
Set Frequency: 15
Freq Manual: Disable/Enable
```

- a. Press [SELECT] to access Test Module for Set EXV1 followed by [CHANGE] or to vary the opening of the electronic expansion valve from 0 to 2000p. Press "SELECT" to choose EXV1 Manual for ENABLE. If DISABLE is selected, EXV manual adjustment is restricted. The default setting by the manufacturer is "DISABLE".
- b. Press [SELECT] or to set for EXV2. Repeat the process as above.
- c. Press [SELECT] or for Set Frequency followed by [CHANGE] or to set the frequency of compressor from 15-110 Hz. Press [SELECT] and [CHANGE] or to set ENABLE, if an inverter compressor is used. If DISABLE is chosen, the setting is invalid. The default setting by Mfg is DISABLE.
After finish parameter change, press [ESC] to exit and enter the previous menu.
- d. If press [SELECT] or to select the setting of Freon anti-frozen protection followed by [CHANGE] or to set "enable" or "disable". After finish parameter change, press [ESC] to exit and enter the previous menu.

- e. To integrate the system with building automation, press [SELECT] for BA Control and [CHANGE]▲or▼ for ENABLE. If BA Control mode is DISABLE, all BA entries will be denied. Select “enable”, press [ENTER] to the next step.

```
BA mode:  Disable/Enable
```

To select BA mode press [SELECT]▲or▼ for BA Mode followed by [CHANGE]▲or▼ to DISABLE or ENABLE. The default setting is DISABLE. When BA Mode is based on "DISABLE", the control of mode of operation is by way of wired handset. When BA Mode is ENABLE, the mode of operation is by way of BA adapter mode selection control signal (Open circuit for cooling, short-circuit for heating). In this case the Wired Handset display mode will synchronize with that of the BA adapter mode. To revert to Wired Handset control Mode, press [SELECT]▲or▼ for default settings.

5. ERROR RECORD

To check the historical error record, press **【ERROR】** for the menu.

ERROR RECORD

```
00/00/00 00: 00 [---] --
00/00/00 00: 00 [---] --
00/00/00 00: 00 [---] --
00/00/00 00: 00 [---] --
```

The historical errors will be in chronological order. Press [SELECT] and scroll up ▲or down ▼ to view the pages.

The panel display is according to year/month /day/minute/second, module address and error code.

This function allows up to 28 errors to be recorded in chronological order and on first-in-first-out basis.

To delete all records, hold down the ERROR key for 6 seconds. To return to main menu, press ESC.

6. MODULE PARAMETERS CHECKING

To check the parameters of the respective module, press **【CHECK】** for MODULE CHECKING followed by **【CHANGE】** ▲▼ to choose from 0 to 15 for the address of the module. Press **【SELECT】** ▲▼ to scroll for the parameters and operating status.

MODULE PARAMETER CHECKING

```
Chiller Typ: HR4D [00]
Comp Status: 1111
Pump Status: On/Off
Flow Status: On/Off
```

CHANGE】 to select module address
 1 Error ON, 0 Compress OFF

```
Panel Temp: 25°C [00]
Ambient Temp: 25°C
Water-out : 25°C
Water-in : 25°C
```

Comp1 Amp: 00.0A [00]
Comp2 Amp: 00.0A
Comp3 Amp: 00.0A
Comp4 Amp: 00.0A

Discharge1: 25°C [00]
Discharge2: 25°C
Discharge3: 25°C
Discharge4: 25°C

A system coil inlet: 25°C [00]
A system coil outlet: 25°C
B system coil inlet: 25°C
B system coil outlet: 25°C

A system BPHE inlet: 25°C [00]
A system BPHE outlet: 25°C
B system BPHE inlet: 25°C
B system BPHE outlet: 25°C

water exchanger

A system Suction: 25°C [00]
B system Suction: 25°C

Parameter1: 0x00 [00]
Parameter2: 0x00
Parameter3: 0x00
Parameter4: 0x00

AC voltage : — [00]
A System EXV: 1500
B system EXV: 1500

Total Comp: 04 [00]
Comp Running: 04
Total Module: 01

14 PCB

PCB photo



Dip-switch setting**1. address setting**

Total of eight bits dip-switch,fore four bits are for module chiller address setting,and moudule chiller network can just have one master unit,and every module chiller's address cannot be same.

The first-fourth bits are for module chiller selection:

DIP1	DIP2	DIP3	DIP4	address
ON	ON	ON	ON	master unit 0
ON	ON	ON	OFF	slave unit 1
ON	ON	OFF	ON	slave unit 2
ON	ON	OFF	OFF	slave unit 3
ON	OFF	ON	ON	slave unit 4
ON	OFF	ON	OFF	slave unit 5
ON	OFF	OFF	ON	slave unit 6
ON	OFF	OFF	OFF	slave unit 7
OFF	ON	ON	ON	slave unit 8
OFF	ON	ON	OFF	slave unit 9
OFF	ON	OFF	ON	slave unit 10
OFF	ON	OFF	OFF	slave unit 11
OFF	OFF	ON	ON	slave unit 12
OFF	OFF	ON	OFF	slave unit 13
OFF	OFF	OFF	ON	slave unit 14
OFF	OFF	OFF	OFF	slave unit 15

Notes:module chiller can connect 16 pieces of units at the most to compose network

Slave address setting had better set as sequence continuously(1、 2、 3by turns adding continuously)

2. Type setting

2.1 the fifth bit setting is for unit type selection

The fifth bit sets "ON",cooling only

The fifth bit sets"OFF",heat pump.

2.2 the sixth bit is for 30 or 70 unit type selection

The sixth bit sets "ON",33C

The sixth bit sets "OFF",65C

NOTES: The last two bits are not difined,and usual set "OFF" when out of factory.

14.fault code

- E01 flow switch fault
Troubleshooting:stop all module chillers
Failure resume:this fault is unresume failure
Must cut off power,after eliminate failures,then restart
- E05 triple-phase AC input lack phase protection
Troubleshooting:stop all compressors、 water pump、 fan motor(if master unit occurs this fault,all modules will stop,slave unit occurs this fault, only corresponding module unit will stop);
Troubleshooting resume:after AC input is normal,will auto resume;
- E06 triple-phase AC input phase sequence protection
Troubleshooting:stop all compressors、 water pump、 fan motor(if master unit occurs this fault,all module units will stop;if slave unit occurs this fault,only corresponding module unit will stop);
Failure resume:after power off,adjust phase sequence,will resume.
- E07 water return sensor fault
Troubleshooting:stop all compressors、 water pump(if master unit occurs this fault,all module units will stop;if slave unit occurs this fault,unit won't do stop protection);
Failure resume:resume after change ambient sensor normally;
- E08 water outlet temp. sensor fault
Troubleshooting:stop this unit's all compressors;
Failure resume:resume after change temp. sensor normally.
- E09 outdoor ambient temp. sensor fault
Troubleshooting: stop this unit's all compressors;
Failure resume:resume after change temp. sensor normally;
- E16 wired controller communication fault
Troubleshooting:system will do "OFF"manage
Failure resume:auto resume after receiving wired controller communication signals.
- E21 fan overload protection fault
Troubleshooting:stop this unit's compressor
Failure resume:unresumable
- E22 A system high pressure protection
Troubleshooting:A system compressor stop;
Failure resume:resume after signals shut;
- E23 A system low pressure protection
Troubleshooting:A system compressor stops;
Failure resume: resume after signals shut;
- E24 compressor 1 over current protection
Troubleshooting:A system compressor stops;
Failure resume:auto resume;
- E25 compressor 1 discharge temp. sensor open circuit or short circuit
Troubleshooting:A system compressor stops;
Failure resume:auto resume after changing sensor normally;
- E26 A system coil(outlet) temp.sensor is open circuit or short circuit
Troubleshooting:stop A system compressor

- Failure resume:auto resume after changing sensor.
- E28 A system water exchange refrigerant entrance port is open circuit or short circuit
Troubleshooting:stop A system compressor;
Failure resume:auto resume after changing sensor normally;
- E29 A system suction temp. sensor is open circuit or short circuit
Troubleshooting:stop A system compressor
Failure resume:auto resume after changing sensor normally;
- E30 A system coil(entrance)temp. sensor is open circuit or short circuit
Troubleshooting:A system compressor stops;
Failure resume:auto resume after changing sensor normally.
- E31 compressor 1 discharge temp. sensor overhigh
Troubleshooting:A system compressor stops;
Failure resume:resume after changing temp. sensor or discharging temp. sensor<90°C
- E32 A system coil (exit) temp.sensor temp. overhigh
Trooubleshooting:A system compressor stops;
Failure resume:resume after A system coil(exit) senor temp.<55°C
- E39 compressor 2 overcurrent protection
Troubleshooting:A system compressor stops;
Failure resume: auto resume;
- E40 compressor 2 discharge temp. sensor is open circuit or short circuit
Troubleshooting:A system compressor stops;
Failure resume:auto resume after change sensor normally;
- E46 compressor 2 discharge temp. is overhigh
Troubleshooting:A system compressor stops;
resume:resume after compressor 2 discharge temp.<90°C
- E52 B system high pressure protection
Troubleshooting:B system compressor stops;
Failure resume:auto resume after signals shut
- E53 B system low pressure protection
Troubleshooting:B system compressor stops;
Failure resume:auto resume after signals shut;
- E54 compressor 3 over current protection
Troubleshooting:B system compressor stops;
resume:auto resume.
- E55 compressor 3 discharge temp. sensor is open circuit or short circuit;
Troubleshooting:Bsystem compressor stops;
Failure resume:auto resume;
- E56 B system coil(exit) temp. sensor is short circuit or short circuit
Troubleshooting:B system compressor stops;
Failure resume:auto resume after changing sensor normally.
- E57 B system water exchange refrigerant entrance temp.sensor is open circuit or short circuit
Troubleshooting:B system compressor stops;
Failure resume:auto resume after changing sensor normally;

- E58 B system water exchange refrigerant exit temp. sensor is open circuit or short circuit
Troubleshooting: B system compressor stops;
Failure resume: auto resume after changing sensor normally.
- E59 B system suction temp. sensor is open circuit or short circuit
Troubleshooting: B system compressor stops;
Failure resume: auto resume after changing sensor normally
- E60 B system coil(entrance) temp. sensor is open circuit or short circuit
Troubleshooting: B system compressor stops;
Failure resume: auto resume after changing sensor normally;
- E61 compressor 3 discharging temp. sensor overhigh
Troubleshooting: B system compressor stops;
Failure resume: resume after changing temp. sensor or discharging temp. overhigh;
- E62 B system coil(exit) temp. sensor overhigh
Troubleshooting: B system compressor stops;
Failure resume: resume after B system coil(exit) sensor temp < 55°C
- E69 compressor 4 overcurrent protection
Troubleshooting: B system compressor stops;
Failure resume: auto resume;
- E70 compressor 4 discharging temp. sensor is open circuit or short circuit
Troubleshooting: B system compressor stops;
Failure resume: auto resume after changing sensor normally;
- E76 compressor 4 discharging temp. sensor is overhigh
Troubleshooting: B system compressor stops;
Failure resume: resume after changing temp. sensor or discharging temp. < 90°C

Sincere Forever

Haier Group

Haier Industrial Park, No.1, Haier Road

266101, Qingdao, China

<http://www.haier.com>